



RESIDENTIAL / CONDOMINIUM



For sliding gates
up to 1000 kg
Speed and force control
(inverter model)

RINO

SLIDING GATE MOTORS

Opening
the gates for you

www.erreka-automation.com

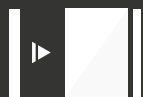

RINO

SLIDING GATE MOTORS



- Obstacle detection
- Magnetic limit switch
- Soft start, soft stop
- Up to 40 openings per hour
- Pushing force retained on slow down *
- Programmable speed *
- LCD programming*

* (mod. 1000EIC-inverter)

TECHNICAL DATA

	RIS600EC	RIS1000EC	RIS1000EIC
Power supply (Vac/Hz)	220/50-60	220/50-60	220/50-60
Absorbed power (W)	280	368	127
Maximum gate weight (kg)	600	1000	1000
Torque (Nm)	20.4	27.0	27.0
Duty cycles (cycles/hour)	15	25	40
Speed (m/min)	11.4		11.4-22
Pinion	M4-Z16		
Protection class (IP)	44		
Operating temperature (°C)	-20 / +55		
Built in control board	yes		
Operator weight (kg)	13.0	14.5	14.5
Use	Residential / Condominium		



INSTALLATION LAYOUT

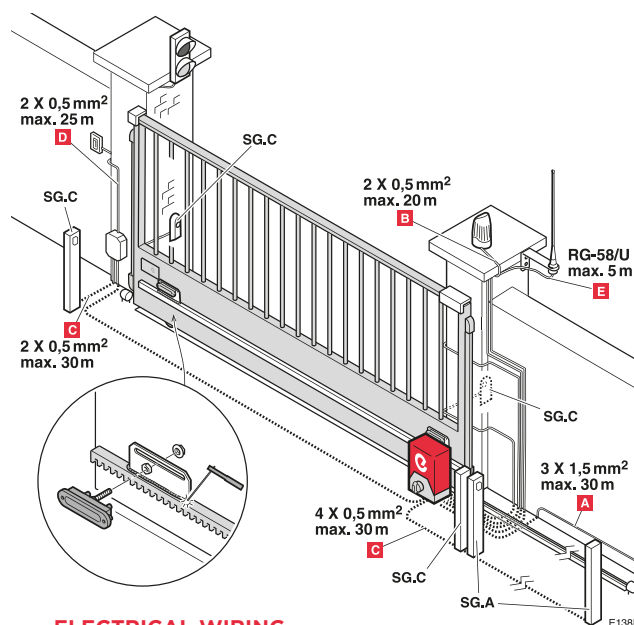

RECOMMENDED ACCESSORIES:

Rack:

N2120 (2m)

Control panel:

AP600S / AP600SI
(Built-in motor)

Radio receiver:

IRRE2-250

Remote control:

LIRA
IRIS

Photocell

FT06

Flashing lamp

LUMI



ELECTRICAL WIRING

- A:** Main power supply
- B:** Flashing lamp
- C:** Photocell (Tx/Rx)
- D:** Push button or key switch
- E:** Antenna