

This quick guide is a summary of the complete installation manual. The manual contains safety warnings and other explanations which must be taken into account. The most recent versions of this guide and the installation manual are available at the "Downloads" section on Erreka's website.  
<http://www.erreka-automation.com>

### WARNING

The options and functions described in this guide apply for the firmware version indicated on the circuit. The firmware, as part of a process of continuous improvement, is subject to new functionalities or upgrades being included as a result of new versions which are not necessarily compatible with previous ones. For this reason, some options or functions may differ or be unavailable if your firmware is older than shown in this guide.

### Elements of the complete installation

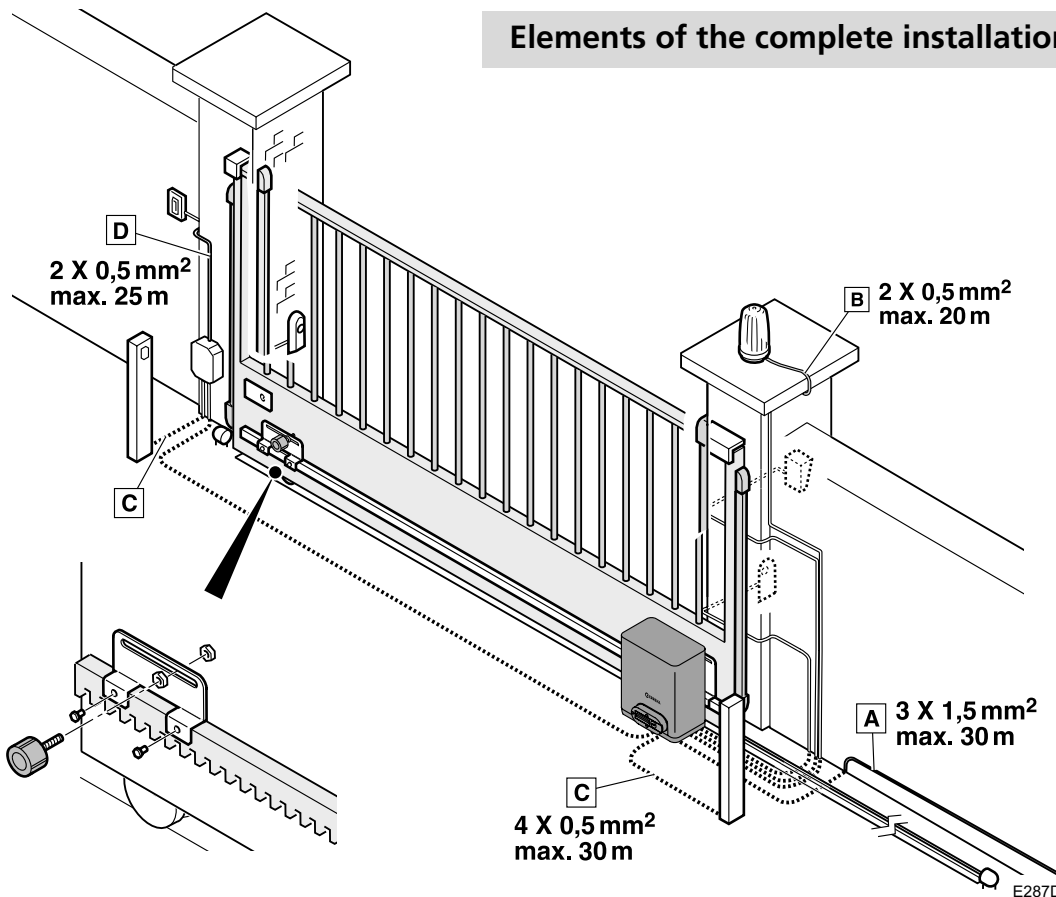

### Electrical wiring

- A: Main power supply
- B: Flashing light
- C: Photocells (Tx / Rx)
- D: Pushbutton/wall key

### Assembly levels (mm)

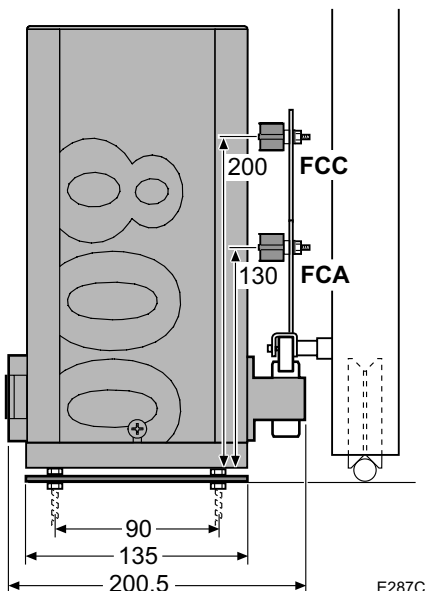

### Manual operation

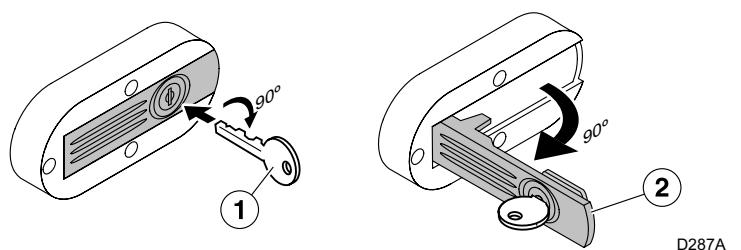

### Unlocking for manual operation:

- Insert the key (1) and turn clockwise about 90°, without forcing it.
- Pull the release lever (2) until it is about 90°, without forcing it.

### Motorised operation locking:

- Proceed in reverse order to release.
- Move the gate manually to interlock it in the operator mechanism.

## General connections

▲ **Ensure the power supply is disconnected before making or changing the connection.**

☞ When the connections are complete, return the control panel cover.

• The panel has a built-in radio receiver (RSD) to receive transmitter signals at 433.92MHz.

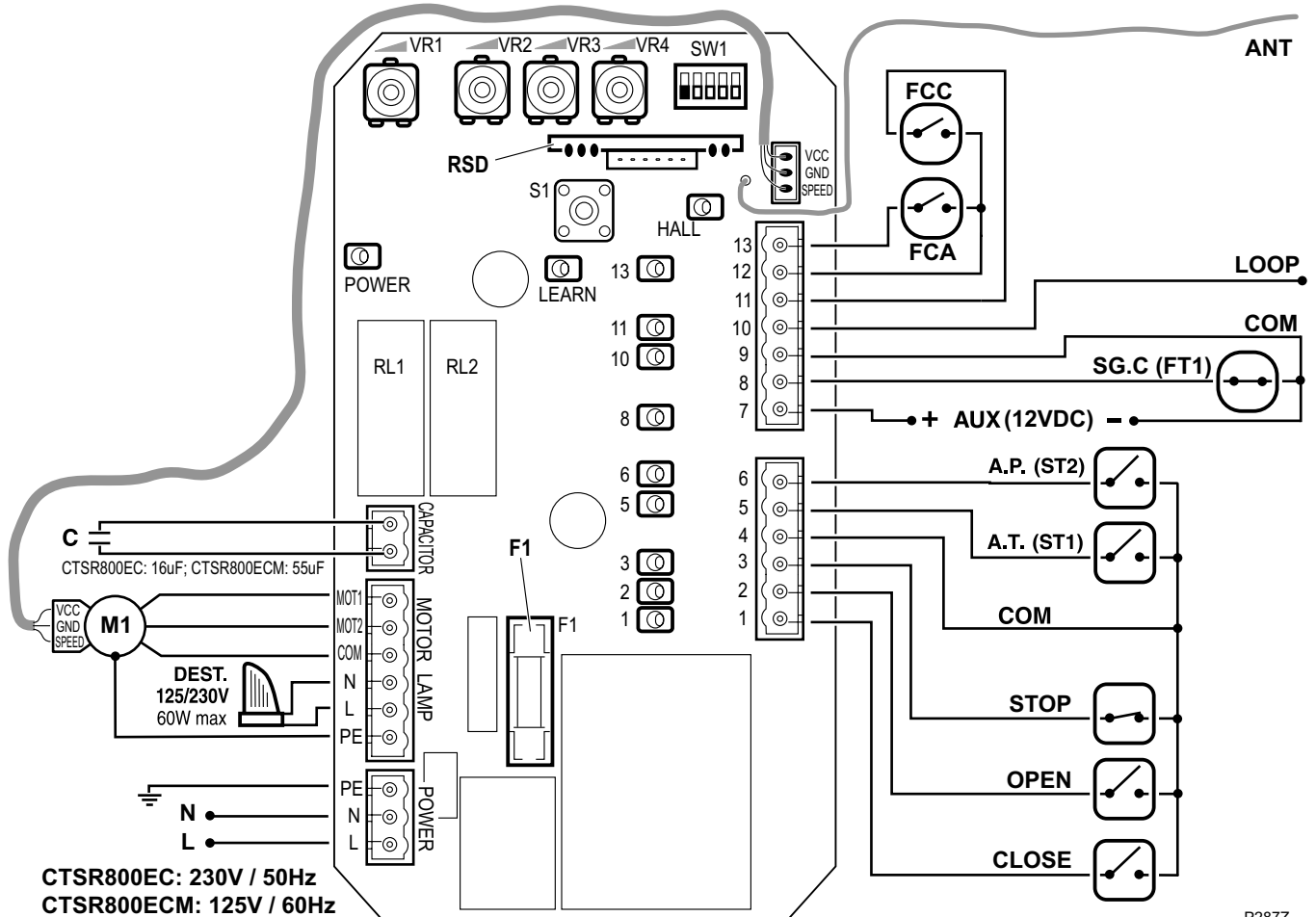

P287Z

### LEDs:

POWER	Power connected
LEARN	Radio programming
LED 1	"CLOSE" pushbutton enabled
LED 2	"OPEN" pushbutton enabled
LED 3	"STOP" pushbutton enabled
LED 5	ST1 pushbutton enabled
LED 6	ST2 pushbutton enabled
LED 8	SG.C Photocell enabled
LED 10	Loop detector (LOOP) enabled
LED 11	Closing Limit Switch (FCC) enabled
LED 13	Opening Limit Switch (FCA) enabled

### Fuse

F1	10A fuse
----	----------

### Connectors:

CLOSE (1)	Close Pushbutton
OPEN (2)	Open Pushbutton
STOP (3)	Stop Pushbutton
COM (4)	Pushbutton Common
A.T. (5)	Total Opening Pushbutton
A.P. (6)	Pedestrian Opening Pushbutton
AUX (12VDC) (7)	12Vdc Auxiliaries supply
SG.C (8)	Closing safety device (photocell)
COM/ GND (9)	Safety Device Common / 12Vdc Auxiliaries supply mass (-)
LOOP (10)	Magnetic loop detector
FCC (11)	Closing Limit Switch
COM (12)	Limit Switch Common
FCA (13)	Opening Limit Switch

☞ **NOTE:** installation can be carried out in two different ways: either using the three "OPEN" (1), "CLOSE" (2) and "STOP" (3) connectors or using the "A.T." connector. When using the latter, it runs sequentially to avoid cyclical Open-Stop-Close orders.

## Turning direction check

**Turning direction:** check operation using the OPEN and CLOSE connectors.

If turning direction is not correct, interchange the motor cables connected to cable connectors MOT1 and MOT2.

## Total opening radio code programming

- 1 Connect the electrical power supply. Press S1 and keep it pressed down for around 2 seconds, until the "LEARN" LED comes on. Release S1 when "LEARN" comes on.

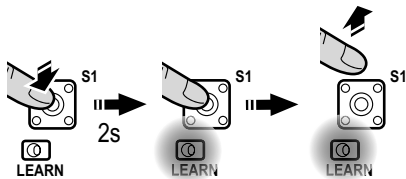

- 2 Press the transmitter button to be programmed while "LEARN" is on (any of the three transmitter channels can be used).

"LEARN" will go off after 2 seconds, indicating that programming is complete.

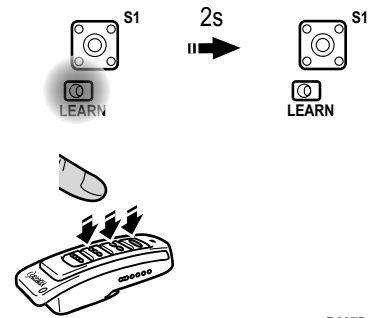

R287B

- Carry out the same process to programme more transmitters if required. The memory can be used with up to 25 transmitters.

## Pedestrian opening radio code

- Pedestrian opening is carried out with the fourth channel button, although it does not need to be programmed: when programming total opening (buttons 1, 2 or 3), number 4 is automatically assigned to pedestrian opening.

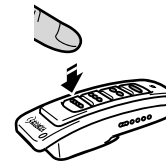

R287C

## Deleting all the transmitters

- 1 Connect the electrical power supply.
- 2 Press S1 until the "LEARN" LED comes on, without releasing it. Keep S1 pressed down until "LEARN" goes off, and then release it. All the transmitters will be deleted.

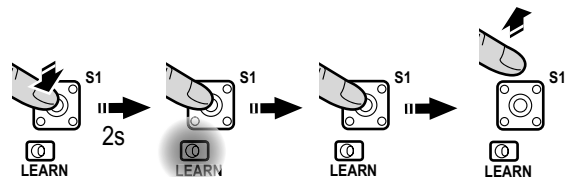

R287D

## Programming the run

- The operator automatically programmes the complete run during the first operation. To ensure programming is correct, the magnetic limit switches must be installed and correctly adjusted in their definitive positions. Maximum run: 12 m.
- Pedestrian opening is 1 metre. This distance is programmed as default and cannot be changed.

## Function and mode selection using SW1

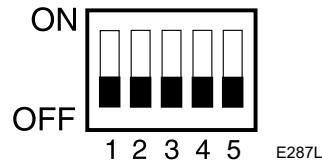

DIP	Modes and functions	Option	Effect
DIP1	Soft start-up	ON	no soft-startup
		OFF	with soft-startup.
DIP2	Limit Switches	ON	Limit Switches normally closed
		OFF	Limit Switches normally open
DIP3 and DIP4	Automatic mode or step-by-step mode	DIP3=OFF and DIP4=OFF	step-by-step mode (the gate only closes when receiving the key command)
		DIP3=OFF and DIP4=ON	12s automatic mode (the gate closes automatically after a 12-second standby)
		DIP3=ON and DIP4=OFF	24s automatic mode (the gate closes automatically after a 24-second standby)
		DIP3=ON and DIP4=ON	36s automatic mode (the gate closes automatically after a 36-second standby)
DIP5	Encoder	ON	encoder disabled (does not perform soft-stop or obstacle detection)
		OFF	encoder enabled

## Potentiometer adjustment

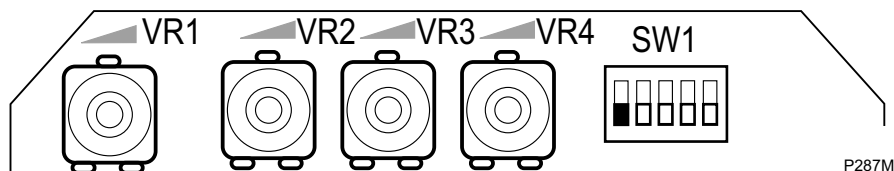

### VR1: Sensitivity in detecting obstacles

The operator has an encoder to detect obstacles and prevent collisions. Sensitivity in detection can be adjusted using this potentiometer.

Turning the potentiometer clockwise decreases sensitivity; turning it anti-clockwise increases it.

### VR2: Braking time

The motor is used to brake at the end of the operation, thus offsetting the inertia of the gate when braking. Adjust the potentiometer to ensure proper braking.

Turning the potentiometer clockwise increases the force; turning it anti-clockwise decreases it.

### VR3: Soft-stop distance

Soft-stop adjustment, where the operator moves at slow speed before reaching the stopper.

Turning the potentiometer clockwise increases the distance; turning it anti-clockwise decreases it.

### VR4: Operator force

Torque or force exerted by the operator during the operation. To ensure safety for people, adjust the force at the lowest value compatible with good operation of the facility.

Turning the potentiometer clockwise increases the force; turning it anti-clockwise decreases it.

**▲ Torque adjustment, respecting the maximum closing forces set out in Standard EN12453:2000. Make the readings as described in Standard EN 12445:2000.**