

# ERREKA



RESIDENTIAL



For gates up to 800 kg  
Magnetic limit switches

**CAT**  
MOTOR FOR SLIDING GATES

We open  
the doors for you

[www.erreka-automation.com](http://www.erreka-automation.com)



# CAT

## MOTOR FOR SLIDING GATES



**Safety. Obstacle detection**  
**Accurate operation with encoder**  
**Electronic soft stop**

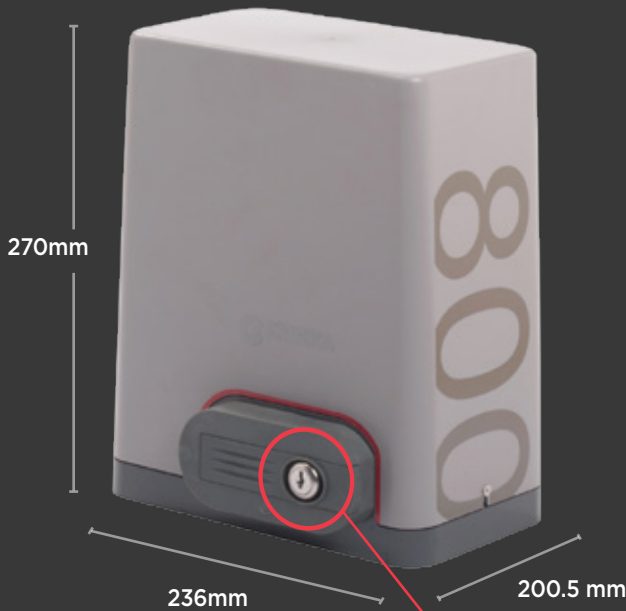

**Practical unlocking**



Built-in 433,92MHz receiver that allows to use up to 20 Rolling Code transmitters.

### TECHNICAL DATA

	CTSR800EC
Power supply (Vac/Hz)	230/50
Power consumed (W)	300
Absorbed current (A)	1,3
Capacitor (µF)	16
Motor voltage (Vac/Hz)	230/50
Maximum torque (Nm)	18
Maximum speed (m/min)	13
Lock	Yes
Limit switches	Yes
Encoder	Yes
Pinion	M4-Z17
Duty cycle	S3 - 20%
Protection level	IP54
Operating temperature (°C)	-20 / +60
Motor weight (kg)	5
Packing dimensions (cm)	27,5x25,5x31,5
Maximum weight of the leaf (kg)	800



### RECOMMENDED ACCESSORIES:

#### Rack

N2120 (2m)

#### Control panel

AP600S / AP600SI  
(Built-in)

#### Receiver

IRRE2-250

#### Transmitter

LIRA

IRIS

#### Photocell

FT06

#### Flashing lamp

LUMI



### INSTALLATION LAYOUT

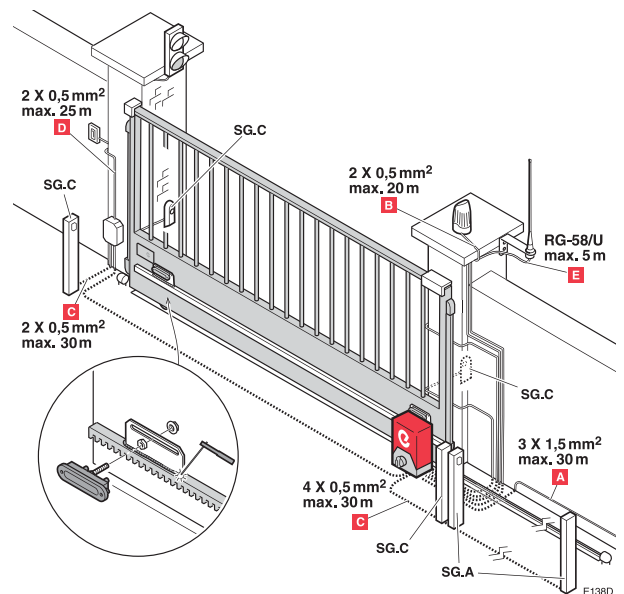

#### ELECTRICAL WIRING

- A.** Main power supply
- B.** Flashing lamp
- C.** Photocell (Tx/Rx)
- D.** Push button or key switch
- E.** Antenna